

Humankind Should Spend Money and Intelligence First Of All for Adapting to Climate Change

Mikhail Krasnyansky*

Dr. of Chemistry, professor, Donetsk Technical University, Ukraine

***Corresponding author:** Mikhail Krasnyansky, Dr. of Chemistry, professor, Donetsk Technical University, Ukraine
Tel: + 380-06239-604-91-28, Email: mykayloo2@gmail.com

Citation: Mikhail Krasnyansky (2022) Humankind Should Spend Money and Intelligence First Of All for Adapting to Climate Change. J Environ Pollut and Manage 4: 105

Abstract

This article is a scientific review, firstly, of the consequences of global warming and climate change, and secondly, of ways for humanity to adapt to these climate changes. The article contains the following sections:

1. Introduction;
2. Hurricanes and Flooding;
3. Wildfires;
4. Green Energy;
5. Green Transportation;
6. Alternative Agriculture;
7. Conclusions and recommendations.

Keywords: Environmental Pollution; Global Warming; Climate Change; Natural Disasters

Introduction

It is already clear for any sensible person: exactly climate change on the Earth has led to a sharp increase in hurricanes, floods, wildfires, droughts and other natural disasters and it led to huge increase of financial damages for federal and local budgets [1].

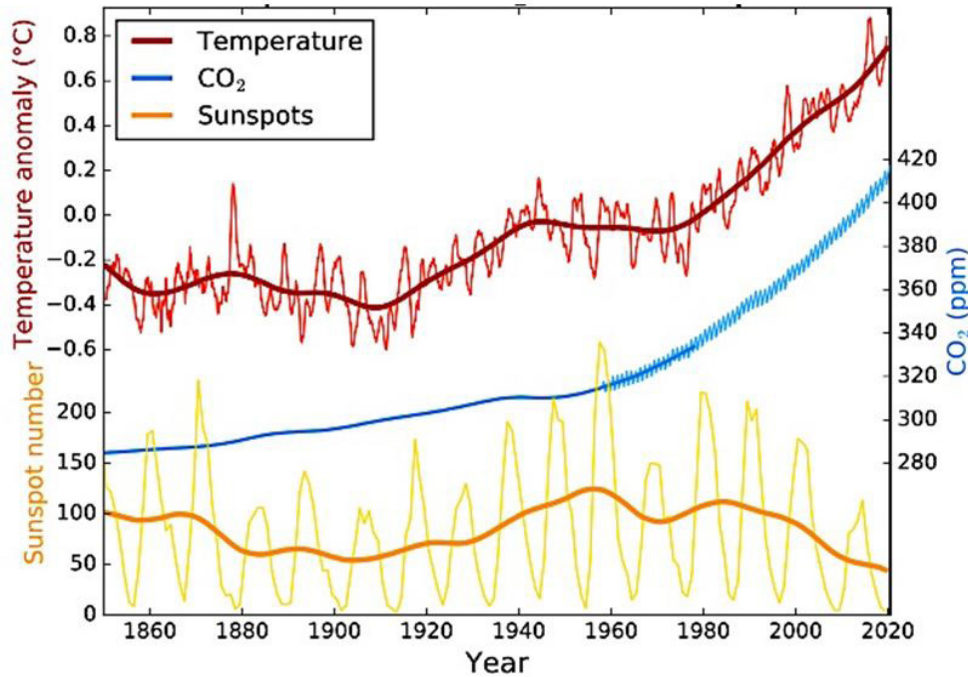

Figure 1: Change in the average temperature of the Earth's surface (red line), CO₂ concentration in the atmosphere (blue line) and solar activity (yellow line) for 1860 - 2020 [2]

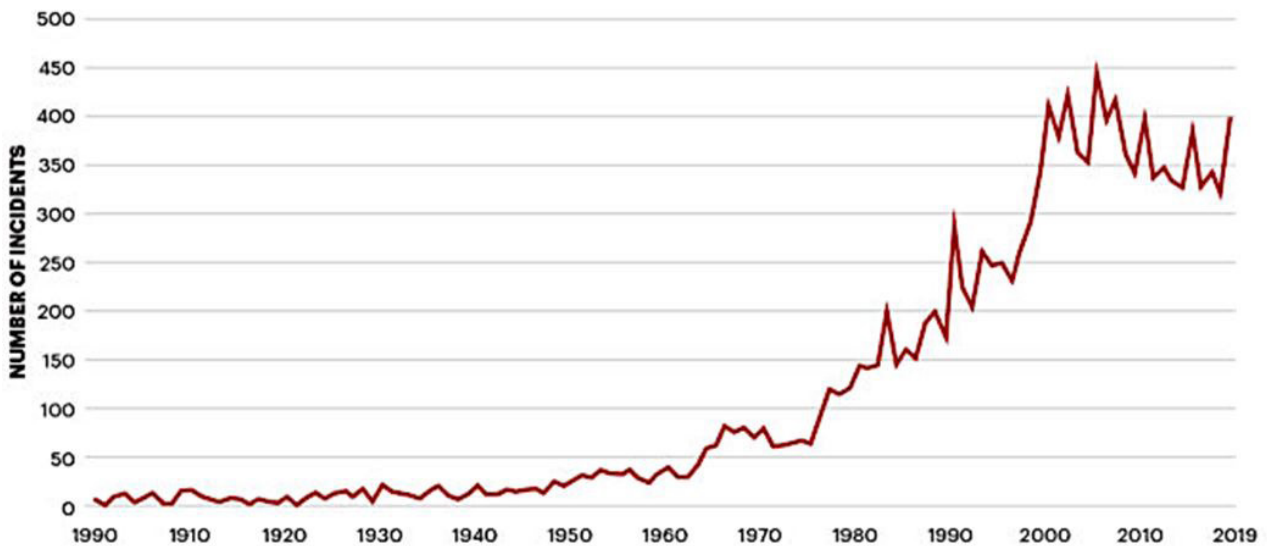

Figure 2: Trend in the number of natural disaster, 1900-2020 [3]

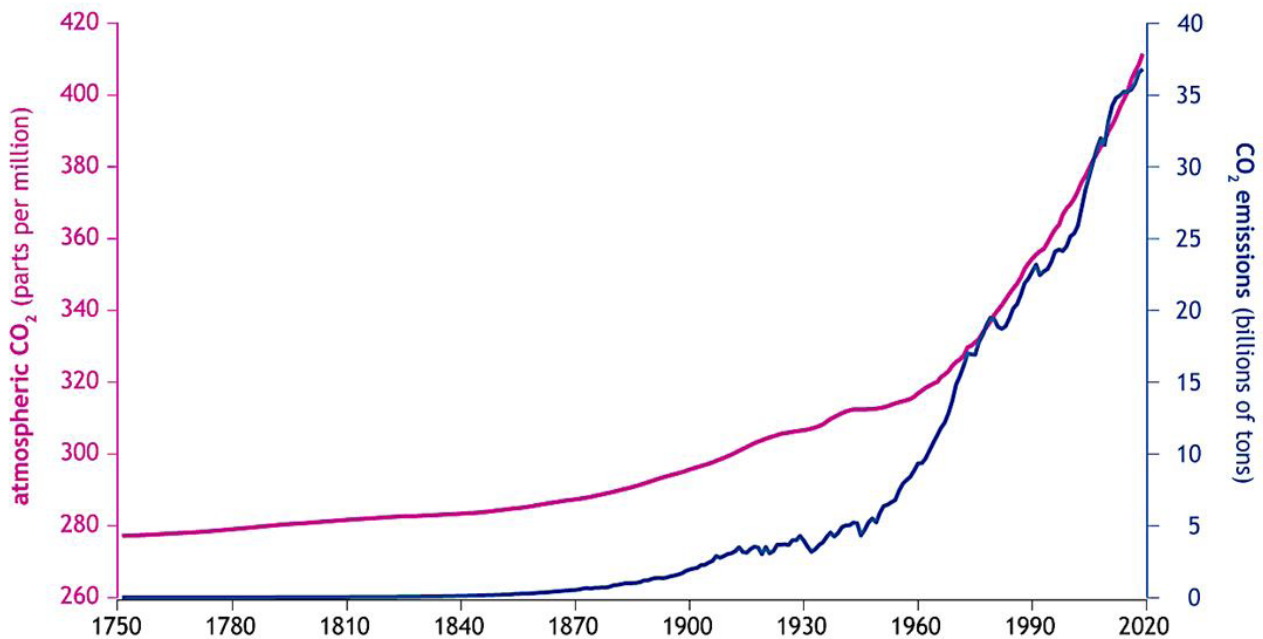

Figure 3: Level carbon dioxide in the atmosphere [4]

As Figures 1, 2, and 3 shows, the turning point (accelerated growth) came about 1960-1970 years.

But the most important (and most alarming) conclusion for scientists was not the fact of “global warming” itself, but the fact that the Earth’s climate is capable of changing much faster and more radically than we thought before, and humanity has no time to adapt to these climate changes neither technologically, nor evolutionary. In addition, some of the changes that have already occurred (an increasing concentration of CO₂ in the Earth’s atmosphere, acidification of the World Ocean with excess CO₂, melting of Arctic/Antarctic ice) are irreversible. For example, the IPCC calculated: in order to significantly avoid consequences of global warming, the world must remove from the atmosphere about 500 billion tons of CO₂ by the end of the 21th century [5]. Also, a 2019 NASA report, indicated that approximately 10 gigatons of CO₂ would need to be removed from the atmosphere each year until 2050 to limit global warming to 1.5°C (2.7°F), that is the goal of the Paris Climate Agreement 2015 [6].

In my opinion, this is really impossible, and this is a senseless waste of huge efforts and huge money. I am sure that the hundreds of billions of dollars allocated in the world for “the fight against global warming” are much more meaningful and important to spend on the adaptation of humankind to new climatic conditions. (Replacing fossil fuels with green energy is also part of humanity’s adaptation to climate change.) As the well-known proverb says: “If the Great Flood is inevitable, one must spend the remaining time learning to live underwater.”

Harricanes and Flooding

Here are some facts

The monstrous hurricane Katrina literally destroyed New Orleans (Louisiana, USA) in 2005. About 80% of the city area was under water, 1836 inhabitants died, about 700,000 people lost their homes, and economic losses reached \$125 billion [7].

Floods in Thailand in 2011: a total of 65 of Thailand’s 76 provinces were affected, 616 people died, more than 1.3 million people sought medical help, 9.5 million people were left homeless. The total damage is estimated at \$16 billion [8].

In July 2021, the state of Maharashtra and neighboring states of India received the heaviest rains in the last 40 years. In some parts of the state, up to 600 mm of precipitation fell per day. The flood caused landslides in various parts of the state. The total number of flood victims reached 213 people. About 230 thousand people were evacuated [9].

In September 2022, Hurricane Ian attacked the state of Florida (USA): 81 people died, hundreds of houses were destroyed, more than 2.6 million Florida residents were left without electricity, and damage was estimated at 40 billion USD [10].

Monsoonal downpours in Pakistan in autumn 2022 triggered floods and landslides that destroyed homes and infrastructure and claimed over 1,300 lives. According to the UN, the elements left tens of millions of people without a roof over their heads. A third of the country's territory is flooded, crops and livestock are destroyed [11].

As can be seen from the above information, humanity around the world is constantly faced with the same consequences of hurricanes and floods:

- A) The destruction of thousands of homes, especially 1-2-storey private residential buildings;
- B) Flooding of vast territories;
- C) Mass de-energization of territories attacked by a hurricane.
- D) Exactly these three factors lead to the death of people there.

Thus, the engineering solutions to prevent these tragic situations are quite obvious, and these solutions have nothing to do with the ineffective "fight against global warming."

The destruction of thousands of homes

It's necessary to allow the construction of only "hurricane-resistant" residential and public buildings in any hurricane-prone areas. This is especially true for 1-2-storey residential houses. It should be monolithic concrete or foam concrete, and even better - reinforced concrete; load-bearing columns must be firmly fixed in the ground (Fig. 4 and Fig. 5) – [12].

All exterior walls and interior load-bearing walls should be supported on reinforced concrete strip footings. Interior walls may be supported by thickening the slab under the wall and suitably reinforcing it. The foundations should generally be located on a layer of soil or rock with good bearing characteristics. By the way, 1-2-3-story residential buildings can be "printed" on giant 3D printers, as startups Shanghai "WinSun" or California's "Icon" do.

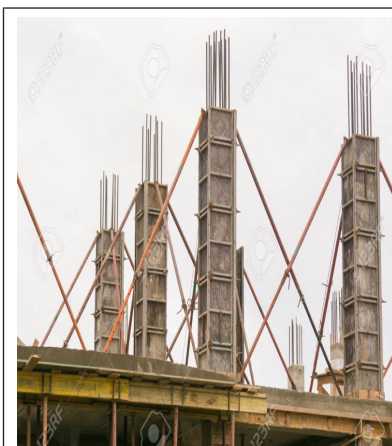

Figure 4: Fill the frame monolithic reinforced concrete buildings, including 1-2-storey residential buildings

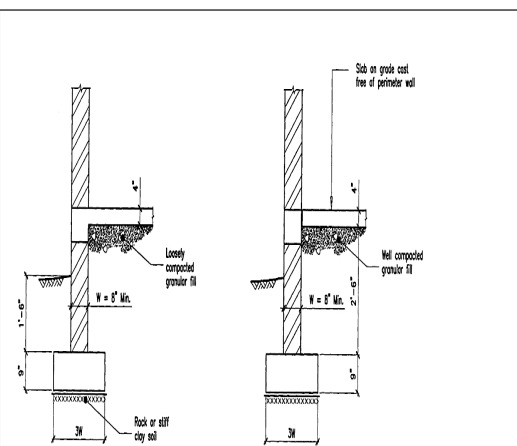

Figure 5: Permissible Arrangement of Footing

Flooding of vast territories

It is necessary in every hurricane- and flood-hazardous region of the world to carry out hydraulic engineering design of the necessary dams, as well as large drainage systems and then build them at any cost.

For example, flood control in the Netherlands began with the arrival of man in these places and continues to this day. The Zuiderzeewerken project included a dam system as well as land reclamation and drainage works. One of the main tasks of the project was the construction of a dam enclosing the large shallow bay Zuiderzee from the North Sea. For this, the Afsluitdijk dam was built, 30 km long, 90 m wide, and 7.25 m high above sea level. In the 1953 flood, the Afsluitdijk dam paid for itself overnight, preventing dangerously high water from invasion of the central regions of the Netherlands [13].

Drainage systems for regions that are regularly flooded are also (like dams) grandiose projects (Fig. 6 and Fig. 7). One of the best, most efficient, and most impressive in the world is Tokyo's drainage system. The Tokyo Drainage System (TDS) [14] is one of the largest and most advanced in the world. It is located 15 km from Tokyo. It is designed to drain water during heavy rains and in case of floods (the average rainfall in Tokyo in the rainiest October is 200 mm; the annual rainfall in Tokyo is 1520 mm). Has 5 huge wells every 1 km, each 70 m in height and 30 m in diameter. Wells connected with each other by large pipes. Pipes diameter 10 m, and all wells are connected by the same pipes to the Edogawa river (through a concrete dam). The main underground hall of the TDS "Bath for Regulation Water Pressure" (it is sealed) has a size of 178x77 meters, a height of 18 m, and the vault is supported by 59 reinforced concrete columns. The TDS gas turbine pumps (located in a separate fortified sealed bunker) are capable of pumping 200 m³/sec of storm water (that's "1 standard swimming pool per second"). Everything is automated and computerized. After the launch of the TDS, the average level on Tokyo's streets of water decreased 10 times. The total area of the system is 6.5 km². TDS had been under construction for 8 years - from 1992 to 1999. Project cost - 2 billion dollars.

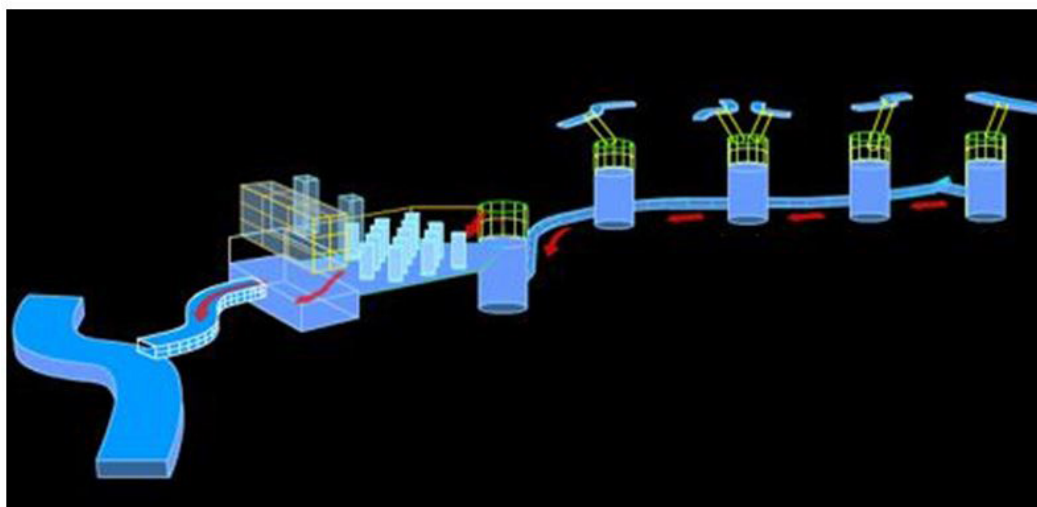

Figure 6: Scheme of the Tokyo drainage system (TDS) (on the right - 5 wells, on the left side - a river)

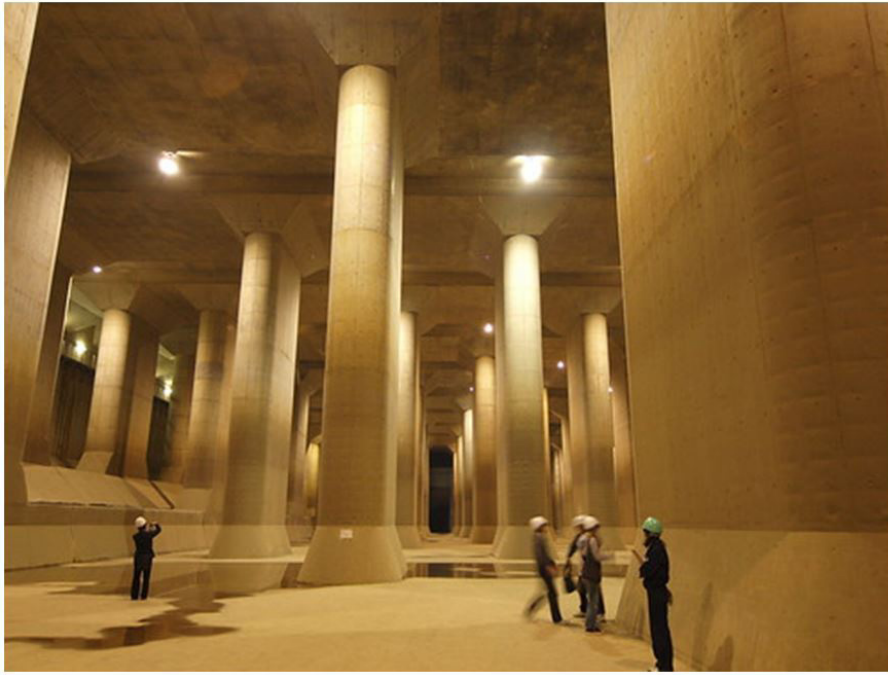

Figure 7: "Water pressure control bath" (size 178x77x18 meters)

Mass de-energization of territories attacked by a hurricane.

Electrical power cables in all hurricane hazardous (as well as fire hazardous) areas should be laid exclusively underground through cryogenic superconducting underground cables, in watertight and heat-resistant shells. Electrical power cables are built above the ground on metallic and even wood pillars, therefore every hurricane or forest fire leaves millions of people without electrical power. (In addition, worn high-voltage power lines are often themselves responsible for forest fires. For example, California-based Pacific Gas and Electric (PG & E) was found guilty for so-called Camp-fire (California, 2018).

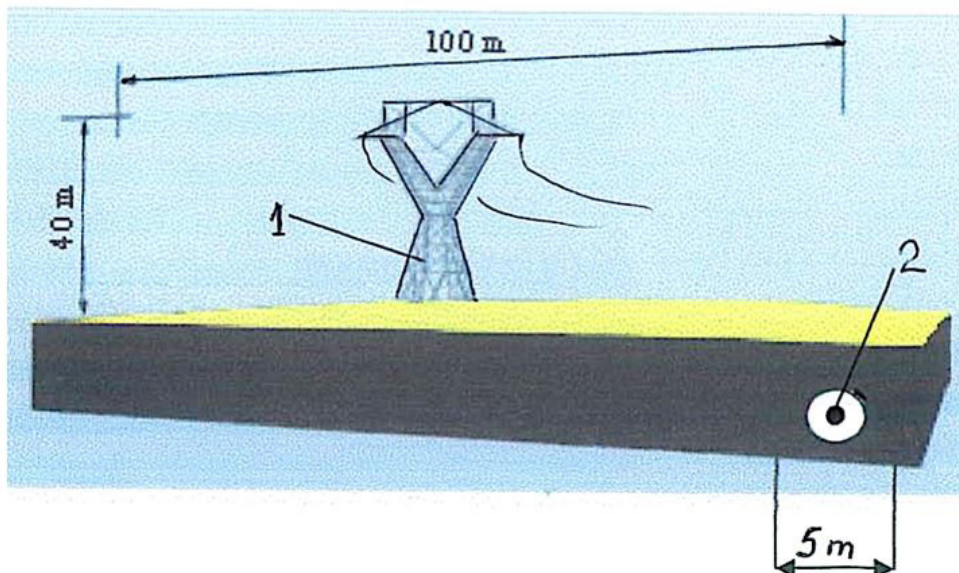

Figure 8: Comparison of conventional high voltage line (1) and cryogenic superconducting cable (2) (<https://www.amsc.com>)

American Superconductor Corporation manufactures cryogenic superconducting cables for high voltage and high current electrical networks. This is a thin copper cable in an empty pipe of small diameter, filled with liquid nitrogen. From above, the pipe (with a cable inside) is reliably covered with hydro- and thermal insulation. The use of such cables for high power networks (5 GW or more) over long distances (1-2 thousand km or more) can bring many benefits. First, the efficiency of power transmission over a superconducting cable is almost 100% (i.e. almost no losses; losses in conventional high-voltage networks - up to 10%). Secondly, a single superconducting cable for a 5 GW line will be ten times thinner than a normal copper cable. Thirdly, a cryogenic cable can be laid underground with a “safety zone” of 5-10 m, while a conventional transmission line of the same power requires a right-of-way 100-200 m wide, and hundreds of metal poles 30-50 m (see Figure 8). And fourthly, I emphasize again, neither hurricanes, nor floods, nor fires will damage such an underground cable.

Wildfires

Wildfires are a huge disaster for our planet: humanitarian (death of people and animals), environmental, economic. In addition, forests are important climate solution, absorbing carbon dioxide equivalent to more than 10% annual greenhouse gas emissions.

In the summer of 2017, more than 120,000 hectares of forest burned out in California, more than 70 people died, about 20,000 houses burned down, and the total damage exceeded \$ 20 billion. Between 2021-2022, wildfires accounted for over \$11.2 billion in damage across the United States [15].

As a result of wildfire in Australia in 2019 (8 million hectares of forests), at least 3 billion animals were affected. More than 60 thousand koalas, more than a million wombats, several million kangaroos died; also, more than 143 million mammals, 2.5 billion reptiles, 180 million birds and 50 million frogs died in the fire [16]. From each hectare of forest fire, up to 100 tons of soot particles and up to 10 tons of toxic fire gases are emitted into the atmosphere [17].

The Dixie Fire in California (2021) was the largest wildfire in the history of the state, covering over 195,000 hectares. Pacific Gas & Electric told authorities that the fire may have started due to a short circuit when a burning tree fell on high-voltage wires. How to prevent and suppress wildfires?

Clean out the old forest and restoring burnt forests

For example, the U.S. Government explained that the nation’s well-intentioned strategy of forest over the past century has created an unnatural buildup of materials that act as kindling for wildfires. We urgently need around the world to start utilizing everything in the forests that kindle: dried twigs, dead trees, grasses, shrubs, even old houses. For example, the area of such forests in the United States (California, Colorado, Oregon, other states) is about 50 million acres and will require about 50 billion dollars for 10 years [18]. Also, the US government has committed to help deliver on global goals to end natural forest loss by 2030, while restoring at least an additional 200 million hectares of forests, to plant an estimated 1.2 billion trees which will sequester 75 million metric tons of carbon [18]. It’s interesting, “Lockheed Martin Corp.” proposes to create new forests and restores the burned-out forests using “seed bombs” (Figure 9). It can be done using the military airplanes C-130 (also known as the “Hercules”) for mass planting trees by bombing. The possibilities are amazing. They can fly on 1,000 ft at 120 knots planting more than 3,000 capsules a minute across the landscape and each capsule contains a sapling.

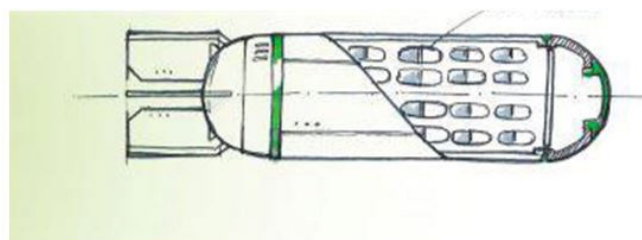

Figure 9: “Seed bomb” (inside container are capsules with tree seeds)

Extinguishing of wildfires

The process of extinguishing the flame has a “threshold” character, i.e. for that it is necessary to have a strictly 100% required amount of the firefighting agent for quite a long time simultaneously in any area of fire (including burning forest) which we extinguish [19]. Otherwise (in case of insufficient quantities of extinguishing agent or during pauses with its delivery), the fire will not subside, but will flare up again and again and spread quickly.

The norm for extinguishing burning firewood is 0.3 kg/m³ of flame (it could be ammonium phosphate). But these 0.3 kg should be in EVERY m³ of burning wood CONTINUOUSLY for at least 30 minutes [19]. The precipitation velocity calculated from the well-known Stokes law for single particles (ammonium phosphate) of 100, 50, and 5 micron diameter are 63, 15, and 0,3 cm/s respectively. However, the precipitation of an aerosol cloud of the firefighting powder inside turbulent flame is a much more complex process.

Therefore, for example, California (and all other fire hazardous regions of the world) should be sufficiently completed by aircrafts and helicopters with large load capacity for fire-fighting. The problem is that the ALL area of the fire must be CONTINUOUSLY covered by a fire extinguishing agent (powder, foam, water). To do this, it needs to have a big squadron of fire planes (several tens), so that when the last plane will drop the fire extinguishing agent on the flame, the first one would have time to recharge and to arrival at the fire. There need a non-stop “aviation fire extinguishing carousel” over the wildfire!

Fire resistant houses

As in the case of hurricane-prone areas, similar recommendations apply for fire-prone areas: it's necessary to allow the construction of only “fire-resistant” residential and public buildings in any fire-prone areas. This is especially true for 1-2-storey residential houses. It should be monolithic concrete (Figure 4). But in this case, it will be the so-called refractory or heat-resistant concrete. Saunas and fireplaces are usually made from such concrete for ordinary housing. Also, for fire hazardous regions, additional processing of the outer layer of concrete with special heat-resistant coatings is necessary. So, researchers at the Nanyang Technological University (NTU) in Singapore have invented an invisible coating that can be applied to wood to make it fireproof. The coating is transparent and just 0.1 mm thick, it is invisible to the naked eye. When exposed to fire, the coating becomes a char that is more than 30 times its original thickness [20].

Since forest fires completely destroy electrical networks, then (as for hurricane-prone regions) for fire-prone regions electrical power cables should be laid exclusively underground through cryogenic superconducting underground cables (see Figure 8).

Green Energy

Sunlight and Wind

The average flow of solar energy reaching the Earth's surface is 200-250 W/sq.m, while human economic activity requires only 15-20 W/sq.m. for highly industrialized countries and no more than 3 W/sq.m for poor countries. That is, theoretically, it is enough to use up to 8-10% of solar energy to fully meet the energy needs of mankind - without the use of fossil fuels at all.

After 2040 (via 20 years only!) solar, wind and hydrogen energy will almost completely replace coal and oil and partly gas. According to UN Environment Programm (UNEP) data, by 2025, 1 “green kWh” of energy will cost as much as 1 “coal kWh”. Electric cars will be on the roads (by 2040 90% of all sold motor cars in the world will be electrical). Aircrafts will fly through electrical energy too. In the total energy balance of world electricity production for 2021 (28,500 terawatt-hours), the share of solar and wind generation exceeded 10% for the first time. Introduction of generation based on renewable energy sources (RES) in the world by 2030-2035. will reach a record level: 740 GW will be introduced in the EU, and the US will be able to provide up to 40% of the country's electricity (about 1500 GW); also, over the next 10 years, offshore wind energy in the world will “add” more than 200 GW [21].

That is, in replacing fossil fuels with green energy (sunlight plus wind), humanity is moving on the right track, and moving quickly and confidently.

Environmental nuclear power

Nuclear power is neither strictly renewable nor fully green for well-known reasons. Natural uranium contains 99.3% of the ^{238}U uranium isotope and only 0.7% of the ^{235}U isotope. However, only the ^{235}U isotope is suitable as fuel for conventional nuclear reactors. Therefore, natural uranium has to be enriched - it is expensive and dangerous as dangerous traditional nuclear power stations in general. The main ways to “more green” future nuclear technologies are as follows:

- 1) Stop using enriched uranium-238 as fuel, switch to unenriched (or depleted) uranium, and even better, safe thorium;
- 2) Switch to nuclear technologies based on fast neutrons, while using unenriched uranium, as well as afterburning highly radioactive waste to their minimum radioactivity in breeder reactors.
- 3) Switch to the production of small modular nuclear reactors (SMNR) with a capacity of up to 300 MW. SMNR can also be used in conjunction with renewable energy sources and improve their efficiency in hybrid cogeneration.

As a result of using the mentioned technologies, not only will it be possible to save up to 25% of natural uranium reserves, but the average burnup of nuclear fuel will become several times greater. Also, the accumulation of dangerous isotopes of transuranium elements in its slag will be several thousand times less.

A series of small modular nuclear reactors (SMNR) is now being created on the basis of the mentioned technologies. For example, Hyperion Power Generation Company (USA) has developed a compact Hyperion Power Module (capacity 25 MW) (Fig. 10). In addition, Terrapower (USA) has created a traveling wave reactor (TWR) that uses depleted uranium and is able to operate for 100 years without fuel refueling. A similar, but ultra-compact 4S reactor (10 MW) has already been developed by Toshiba (Japan), whose operation life is 30 years without fuel refueling.



Figure 10: Hyperion Power Module (its size is comparable to the size of an elephant)

In addition, the US Department of Energy recently selected 5 of small modular nuclear reactors (SMNR) to receive government support:

- BWXT's Advanced Nuclear Reactor, a mobile microreactor using TRISO fuel for use in remote areas with no centralized power grid (TRISO is the most efficient and safest nuclear fuel in the world);
- Westinghouse eVinci microreactor, also using TRISO fuel;
- Hermes reactor - a smaller version of the high-temperature Kairos Power reactor using molten fluoride as a coolant (KP-FHR);
- Pressurized water reactor SMR-160 developed by Holtec;
- Molten salt (molten chloride) reactor developed by Southern Company Services Inc.

Producing of Electrical Power from Environmental Heat through the Giant Heat-Pumps (project M. Krasnyansky)

Unfortunately, human civilization stepped on a dangerous and inefficient way of energy production by incinerating fossil fuel (coal, gas, oil). However, I would like to pay attention to the fact that the nature has created other grandiose thermal energy source for mankind - it is so-called “secondary” solar energy (i.e. utilization of heat of the upper layers of oceans, seas, rivers, and also of ground and the lower layer of the atmosphere). This “secondary” solar energy can be utilized with the help of large heat- pumps and Stirling-engines (it is an engine of external combustion).

If to combine in a united cycle a heat-pump, the Stirling-engine and heat-exchanger (Figure 11, 12) - we shall have so-called “non-fuel power station” (NFPS), where transformation of heat into useful mechanical work will occur with efficiency up to 80% (Figure 13).

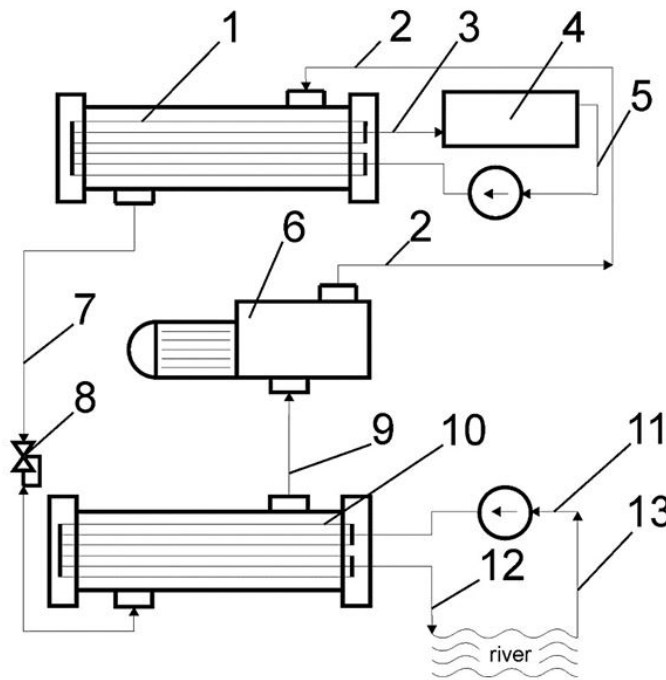

Figure 11: The scheme of a “non-fuel” power station (NFPS):

1 – condenser; 2 – compressing of more hot gasiform-ammonia (+ 80 °C); 3 – more hot water (+ 70 °C); 4 – heat-exchanger, combined with the Stirling-engine and the electric-generator; 5 – less hot water (+ 30 °C); 6 – compressor; 7 – compressing of the less hot gasiform – ammonia (+30 °C); 8 – choke; 9 – fluid-ammonia (- 40 °C); 10 – evaporator; 11 – less cold water (+ 10 °C) from river; 12 – more cold water (+ 5 °C) into river

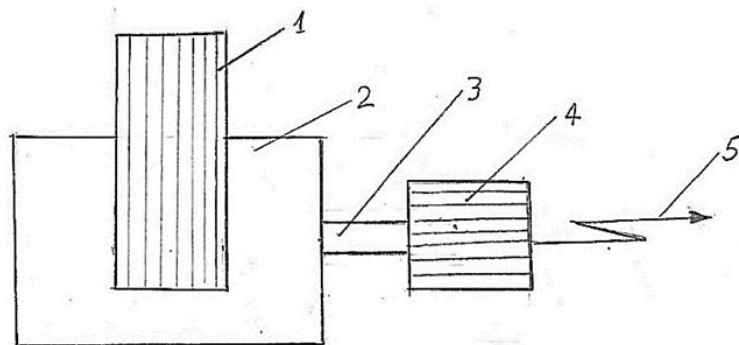

Figure 12: Position 4 of the Figure 11 (in detail):

1 - external combustion chamber of the Stirling-engine (it is engine of external combustion); 2 – heat-exchanger of the NFPS; 3 – shaft of the Stirling-engine; 4 - generator of an electric current; 5 – electric current for consumers

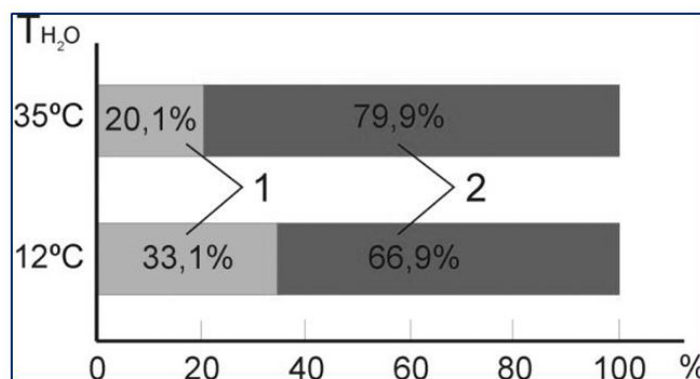

Figure 13: Heat-pump efficiency^[1]

1 -energy spent for work of the heat-pump; 2 - energy received from work of a NFPS

The heat pump works like a “refrigerator in reverse” - the interior heats up, and the environment (a section of a river, ground or surrounding atmosphere) cools. The heat carrier here is liquid ammonia (-40 °C). Therefore, if a coil with liquid ammonia is immersed in a river (lake) or buried in the ground, then even in winter at (-5 °C), this water or ground will be “hot” for liquid ammonia, and it evaporate and will perform work, and water (ground) around the coil - will be cooled. In this case, the NFPS system produces much more energy than it consumes for the operation of the heat pump.

Herewith^[1]

- Using of fossil fuel will be decreased^[1]
- The negative change of a climate will be decreased^[1]
- Pollution of the environment by toxic smokes and dust will be decreased^[1]

In fact, the use of the NFPS is a unique way to combat “global warming” because it will pump out superfluous heat from the environment. However it should be understood: if we want high efficiency, then we mean the GIANT heat pumps and GIANT thermodynamic cycles.

Zero-Energy Houses

In the last decade, the world has become popular with so-called “zero-energy house”, i.e. buildings that are highly energy efficient, able to independently generate and save energy and consume it from its own sources throughout the year [22]. Such buildings are now being intensively built around the world: FKI Tower and “Dancing Dragons”, (Seoul, South Korea), Hikari Lyon (France), New-Blauhaus (Mönchengladbach, Germany), Manitoba Hydro Place (Winnipeg, Canada), Clean Technology Tower (Chicago, USA), others. So, China built a 300-meter 70-story “Pearl River Tower” in the city of Guangzhou – figure 14. It’s a skyscraper with “zero energy”!

That is, it will not consume electricity from the external network, and will also consume almost no water. The house will use wind and solar energy. The curved facades of the Tower are designed to direct the wind into special “vents blown through” that are on each of the floors and where wind turbines are installed. Along the façade, there are rows of solar panels (photovoltaic panels) that supply electricity to the home’s batteries. In addition, solar thermal collectors are installed on the building, which heat water for the inhabitants of the skyscraper. The project includes a rainwater collection system, as well as a wastewater treatment and recycling system, which should minimize the house’s need for an external water source.



Figure 14: Zero-energy skyscraper «Pearl River Tower» [23] (spiral “wind vents” are visible on the right side of the house, solar panels are on the facade)

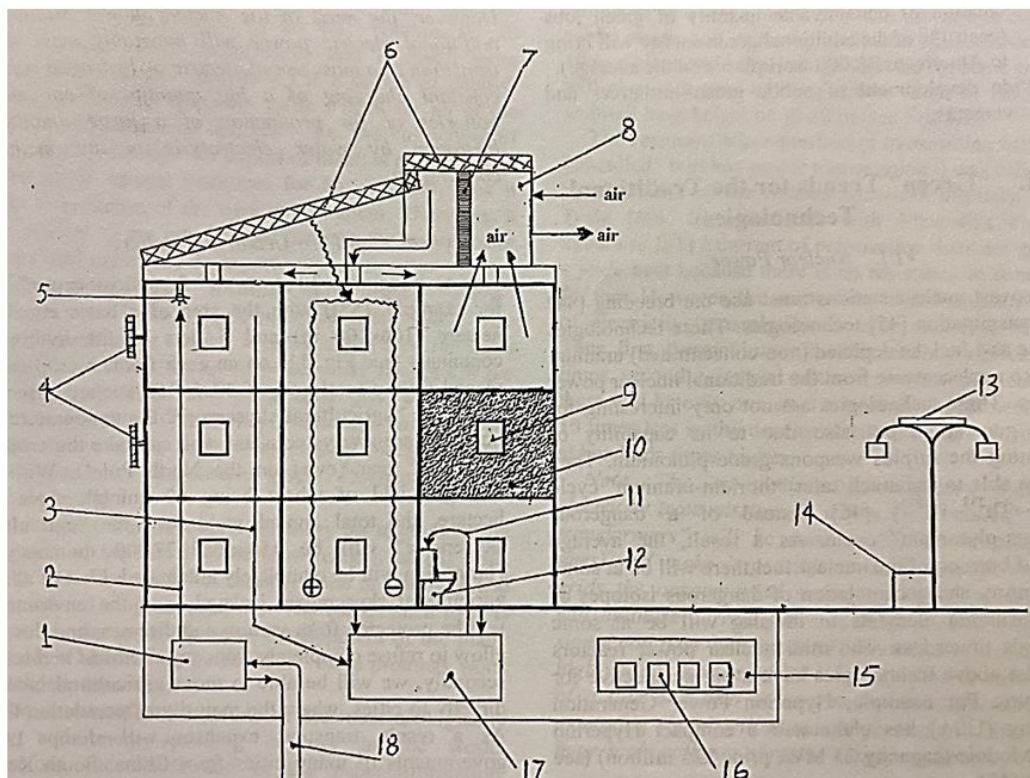

Figure 15: Zero-Energy-House (project M. Krasnyansky):

1 – heat-pump; 2 – warm water; 3 – cool water; 4 – micro-wind-turbines; 5 – light-emitting diode; 6 – solar panel; 7 – air filter; 8 – air-exchanger; 9 – “photovoltaic windows” that serve as an additional electricity generators; 10 – super-insulation; 11 – water after cleaning; 12 – toilet; 13 – solar panel; 14 – electrical accumulator; (13 and 14 – are a street lamppost with independent generation of the electric power); 15 – laundry; 16 – “dry” washing-machines (without using of water and any detergent); 17 – bio-chemical cleaning of the sewage; 18 – coil with liquid ammonia;

Green Transportation

Currently, more than one billion internal combustion engines are in operation in the world (cars and trucks, diesel locomotives, tractors, agricultural and construction equipment, armored vehicles, airliners, etc.), which annually burn about one and a half billion tons of motor fuel (gasoline, diesel fuel, jet fuel), and they pollute the atmosphere with toxic and greenhouse gases.

The efficiency of an internal combustion engine is low - at best 30%, on average 25% (see Figure 16).

Volkswagen (<https://www.volkswagen-newsroom.com/en>) gave interesting statistics for Europe: the average speed of urban transport in the majority is 22 km/h; however, with such meager indicators, these cars consume an average of [10 (cars) -15 (pickup trucks, minibuses) - 25 (buses)] liters of motor fuel per 100 km. Most of this fuel is burned at traffic lights or traffic jams; for small trucks - also for small loading and unloading; in the case of passenger transport - at stops with the engine running.

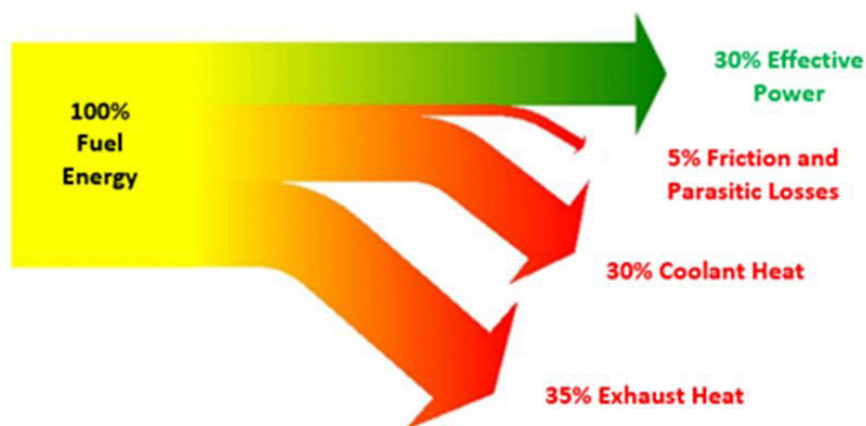

Figure 16: Gasoline engine efficiency diagram (AAA image)

Therefore, the US, EU, China, and Japan have already committed themselves to completely stop the production of gasoline and diesel cars by 2040 and switch to electric vehicles. As for urban and intercity transport, it also needs to be converted to electricity, or at least replaced with “hybrids”, so that at traffic lights, in traffic jams or at stops, it does not waste fuel in vain, but charges its battery.

Alice, an electric aircraft developed by Israeli startup Eviation (<https://www.eviation.com>), flew to 3,500 feet and stayed in the air for 8 minutes. Alice is a nine-seat regional aircraft for two crew members and nine passengers with a range of up to 830 km and a speed of up to 460 km/h; load capacity 1.1 tons.

That is, in replacing traditional gasoline and diesel vehicles to electric one, humanity also is moving on the right track, but not moving fast enough.

Alternative Agriculture

Agriculture is one of the most powerful sources of greenhouse gases. When sowing, harvesting, transporting agricultural products around the world, millions of tons of gasoline and diesel fuel are burned. Cattle breeding creates additional problems. Here there is a low efficiency of the conversion of vegetable proteins into animals. So, it is necessary to grow approximately 8-10 kg of vegetable protein in the form of forage for cattle in order to produce 1 kg of animal protein in the form of, for example, beef, that is, the energy efficiency of this process is only 10-15%. Also, animal husbandry requires 4-5 times more water than forage production: 15,000 liters of fresh water is needed to produce 1 kg of beef, and only 4,000 liters to produce 1 kg of beans. In addition, a typical cow “produces” and releases into the atmosphere 400-500 liters of the greenhouse gas methane (which is a side effect of its digestive processes) per day, and there are about 1.5 billion cows in the world. I.e. cows is responsible for 10% of total greenhouse gas emissions [24]. By the way, vegetable protein (which contains all eight “essential” amino acids) is significantly superior to cattle meat in all medical, environmental and economic indicators!

The way out for humanity is, first, a complete rejection of cattle breeding (with the preservation of much more environmentally friendly poultry farming) and the transition to “artificial meat” and “artificial milk”; secondly, partial transfer of crop cultivation to large cities with help of the so-called “vertical farms”.

Artificial meat (Cultured meat, Grown meat)

The process of producing artificial meat involves obtaining stem cells from animal muscles and using a special protein that allows the cells to grow into larger pieces of meat [25, 26]. An artificial “meat plant” requires much less land (only 1% of the land compared to a conventional farm of the same meat productivity). In addition, under sterile artificial conditions, you can get an environmentally friendly product, without any toxic metals, worms, giardia and other “troubles” that are often present in raw meat. Also, artificially grown meat does not violate moral standards: there will be no need to raise livestock, and then ruthlessly kill them. Growing meat in vitro requires five times less energy and 10 times less water than conventional production of the same amount of beef, and reduces greenhouse gas emissions by 20 times compared to raising livestock for slaughter. By the way, Microsoft founder Bill Gates, Google co-founder Sergey Brin, and famous actor Leonardo DiCaprio invested in the development of artificial meat.

The Good Meat company [27] plans to start building the complex of the world’s largest bioreactors for the production of artificial meat. Commissioning of the equipment is scheduled for the end of 2024. The company plans to grow artificial beef and chicken.

There is also vegetable (vegan) meat (it is made from vegetable protein - pea, bean, and vegetable oil (usually rapeseed). Such “meat” is manufactured and sold by Beyond Meat Corp. (<https://www.beyondmeat.com/en-US/>).

Perfect Day (<https://perfectday.com>), a Silicon Valley startup, has developed “artificial milk” technology. Perfect Day uses a completely new technology: its “milk” is produced by yeast. To do this, nutritional yeast DNA was genetically modified so that the microorganisms produced milk proteins, including casein, lactoglobulin and lactalbumin. The company believes that its technology could become the basis for creating imitations of many dairy products, from cheeses to yogurts.

The American startup Brown Foods (<https://www.ycombinator.com/companies/brown-foods>) has introduced artificial milk made using cell culture technology. The founders of the startup claim that the resulting product is similar in properties and texture to cow’s milk. Startup slogan is: “Making real milk without any cows!”

The Vertical farms

A vertical farm is a highly-automated agriculture-industrial complex for growing crop plants using hydroponics or aeroponics methods indoors inside a specially designed building. The main differences between vertical farms and traditional greenhouse farms are multi-tiered plantings (Fig. 17) and fully controlled indoor climate. The modern use of multi-level racks in combination with LED-based phyto-lighting, irrigation and fertilizer automation, allow vertical farms to increase yields per unit area by 5 or more times compared to traditional farming methods. It is noted that production on a vertical farm is about ten times more efficient than in greenhouses and a hundred times more efficient than in an open field [28].

Vertical farm projects have the following benefits [29]:

- crop stability, which does not depend on natural conditions;
- application of water collection and purification systems that allow reducing water consumption by 95% compared to traditional agricultural production;
- closed ventilation cycle, purification and ionization of air in the growing rooms, which makes it possible to exclude the occurrence of pests and phyto-pathologies, as well as the use of pesticides, herbicides and insecticides;

- possibility of location within city limits, in particular, in repurposed industrial infrastructure facilities, which reduces transportation costs and transportation losses by dozens of times;
- energy independence (when using solar and wind energy).



Figure 17: Vertical farming with hydroponics (for each farm floor) (by Amy Wilson, MSc)

Losses in food chains

According to the World Health Organization, in 2020, out of 7.5 billion people living on the planet, about 800 million people were partially or completely hungry. The world annually produces about 4 billion tons of food, and this could be enough for all the inhabitants of the planet if food was rationally used and distributed.

Food disappears at all stages of production - during collection, processing, storage, transportation to retail chains and food outlets [30].

Globally, around 14 percent of food produced is lost between harvest and retail, while an estimated 17 percent of total global food production is wasted (11 percent in households, 5 percent in the food service and 2 percent in retail) [31]. But in the so-called developed countries, this figure is even higher, for example, in the United States, about 30% of food is thrown away (on average, an American family of four throws away \$2,000 worth of food every year) [32]. At the same time, it must be emphasized that we are not talking about food waste, but about food products suitable for consumption. Thus, we are not talking about, for example, potato peels, but about unused, usable potatoes, which became “food waste” only after they were thrown into the trash can.

The result is that unused food consumes about a quarter of all freshwater consumed, as well as 300 million barrels of oil per year.

Thus, measures to prevent large crop losses, and especially extensive measures to prevent usable food from being wasted, will not only help overcome hunger on the planet, but also prevent the useless burning of millions of tons of oil products, which will significantly reduce the emission of greenhouse CO₂ into the atmosphere.

The Sick World Ocean

The World Ocean is a great helper of humankind in adapting to climate change. UNESCO Director-General Audrey Azoulay said: “The ocean is the heart of our planet. Humanity cannot live healthy if our oceans are sick.”

The world's oceans absorb more than 90% of the excess atmospheric heat and about a third of the carbon dioxide emitted by industry and transport. As the analysis showed, for the entire period of observations (1955-2020), the thermal energy stored in the waters of the World Ocean increased by 380 zettajoules (zetta is 10^{21}). More than half of this heat is concentrated in the upper layers of the ocean (at a depth of up to 200 m). Warmer oceans contribute to severe storms and hurricanes, and increase the risk of flooding [33].

Also, due to the greatly increased content of CO_2 in the atmosphere (and, consequently, its high partial pressure), the World Ocean absorbs an increased amount of CO_2 . So, for 13 years (from 1994 to 2007), the World Ocean "removed" from the atmosphere 34 billion tons of CO_2 , which is about 30% of the total global CO_2 emissions for this period [34]. Scientists believe that this level of CO_2 uptake by the ocean will continue for many more years. As a result of which acidification of the World Ocean occurs, i.e. decrease in pH (since 1890, ocean acidity has increased, and pH has fallen from 8.2 to 8.1, and in some areas even to 8.0) [35]. (For example, although it is still weakly alkaline water, it is no longer alkaline enough for corals, molluscs, and other marine organisms, and they die en masse.)

By absorbing excess heat and carbon dioxide, the oceans slow down climate change, but this negatively affects aquatic ecosystems. After all, the World Ocean is also a source of food and livelihood for several billion people on the planet.

Unfortunately, the oceans are increasingly turning into the world's garbage dump. For example, a huge floating "island" of plastic debris was found on the surface of the Pacific Ocean between California and the Hawaiian Islands [36] (Figure 18 and 19). The mass of plastic is estimated at three million tons (80% - plastic bottles and containers), and the area is about 1 million square km. But research conducted by the Australian scientists has shown that there are additionally about 15 million tons of plastic waste less than 5 mm in diameter at the bottom of the world's oceans, and this is 5 times the mass of plastic that "floats" on the surface of the ocean - 3 million tons. Plastic debris in the Pacific is responsible for the deaths of millions of seabirds and marine animals. Thus, Spanish environmentalists in 2018 found more than 29 kilograms of plastic in the stomach of a dead 10-meter sperm whale [37].



Figure 18: Part of the "garbage island" of plastic in the Pacific; photo The Ocean Cleanup

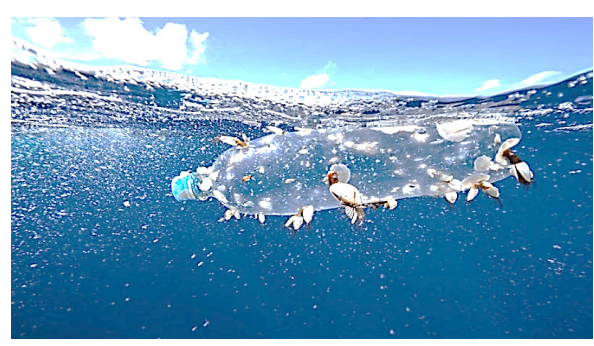

Figure 19: Plastic bottle from the "garbage island"; photo Justin Hoffman (Greenpeace)

As can be seen from Figure 19., a plastic bottle from the "garbage island" is literally covered with mollusks, crabs, and barnacles that bite off microparticles of plastic from the bottle. These clams and crabs will then be eaten by larger fish, and these microplastics will move up the food chain, ending at the human dinner table.

How to protect the World Ocean from plastic waste?

A) Avoid plastic bags. The US and Europe, then Canada and Australia are phasing out plastic bags. Kenya and Tanzania have recently joined. The new rules will force shoppers to reorganize: if they previously received plastic bags for free in stores, now they will be forced to carry their own shopping bags with them or buy cloth bags at the store checkout for little money.

B) For plastic bottles and plastic containers - the transition to biodegradable plastic. Such plastic has already been created in laboratories (<https://www.sciencenews.org/>). Bioplastics are plastic materials produced from renewable biomass sources. So, scientists from University of California, Berkeley develop such plastic for packaging. With moderate heat, enzyme-laced films of this plastic disintegrate within some weeks. British startup Polymateria has also developed a completely biodegradable plastic.

Conclusions and recommendations

The recipe for solving all the previous problems of mankind was the transition to a higher technological stage: from a raw food diet to making a fire, from picking berries and nuts to settled agriculture, from the Stone Age to the Iron Age, from a horse to a “Ford”. Climate change problems must be tackled in the same way.

An analysis of the changes in the conditions of human life on Earth allows us to draw the following conclusions:

1. Exactly climate change on the Earth has led to a sharp increase in hurricanes, floods, wildfires, droughts and other natural disasters and it led to huge increase of financial damages for federal and local budgets.
2. In replacing fossil fuels with green energy (sunlight plus wind), humanity is moving on the right track, and moving quickly and confidently. In replacing traditional gasoline and diesel vehicles to electric one, humanity also is moving on the right track, but not moving fast enough.
3. It's necessary to allow the construction of only “hurricane-resistant” residential and public buildings in any hurricane-prone areas. This is especially true for 1-2-storey residential houses. It should be monolithic concrete or foam concrete, and even better - reinforced concrete; load-bearing columns must be firmly fixed in the ground.
4. As in the case of hurricane-prone areas, similar recommendations apply for fire-prone areas: it's necessary to allow the construction of only “fire-resistant” residential and public buildings in any fire-prone areas. This is especially true for 1-2-storey residential houses. It should be monolithic concrete (Figur. 4). But in this case, it will be the so-called refractory or heat-resistant concrete.
5. In areas prone to flooding, it is necessary to design and build powerful dams and powerful drainage systems like the Tokyo drainage system.
6. Electrical power cables in all hurricane hazardous (as well as fire hazardous) areas should be laid exclusively underground through cryogenic superconducting underground cables, in watertight and heat-resistant shells.
7. Fire hazardous regions should be sufficiently completed by aircrafts and helicopters with large load capacity for fire-fighting. All areas of the fire must be CONTINUOUSLY covered by a fire extinguishing agent (powder, foam, water).
8. To prevent wildfires, we urgently need to start utilizing everything in the forests that kindle: dried twigs, dead trees, grasses, shrubs, even old houses. It will be faster to restore burnt forests with the help of “seed bombs”.
9. It is necessary to return to nuclear power, but to small modular nuclear reactors (SMNR) with a capacity of up to 300 MW. With their help, low-enriched uranium and even nuclear waste from traditional reactors can be used as fuel.
10. We need to use heat pumps much more to generate heat.
11. The world has become a popular so-called “zero-energy house”, i.e. a building that is highly energy efficient, able to independently generate and save energy and consume it from its own sources throughout the year.

12. It is necessary to abandon cattle breeding (while maintaining a more environmentally friendly poultry farming) and switch to artificial meat and milk.

13. Cultivation of agricultural crops should be transferred into the so-called vertical farms. A vertical farm is about ten times more efficient than in greenhouses and a hundred times more efficient than in an open field.

14. Minimize food wastage at all stages - from harvesting and storing crops to discarding expired products.

15. It is necessary to completely abandon the current bio-non-degradable plastic in favor of biodegradable plastic.

After reading this section, any government official will say: "It's all too expensive!" Well, but 20-30-40 billion dollars damage every year - is it NOT expensive?...

References

1. Intergovernmental Panel on Climate Change (IPCC) climate report 2020. <https://www.ipcc.ch>
2. <http://berkeleyearth.org/global-temperature-report-for-2020/>
3. <https://www.visionofhumanity.org/global-number-of-natural-disasters-increases-ten-times/>
4. Monnin E., Indermühle A., Dällenbach A., et al (2001). Atmospheric CO₂ Concentrations over the Last Glacial Termination. *Science*, 291 (5501), 112-14.
5. The climate impacts we saw in 2021 (2021) The Climate Reality Project, December 22. <https://www.climaterealityproject.org/blog/climate-impacts-we-saw-2021>.
6. NASA, NOAA Analyses Reveal 2019 Second Warmest Year on Record. January 15, 2020. <https://climate.nasa.gov/news/2945/nasa-noaa-analyses-reveal-2019-second-warmest-year-on-record/>
7. Knabb, Richard, Rhome, Jamie, Brown, et al. (2005) Tropical Cyclone Report: Hurricane Katrina. August 2005 (PDF).
8. Summary Report of Floods, Storms and Mudslides No. 129 dated January 17, 2012
9. Thailand Emergency Operation Center report for Flood, Storm and Landslide. January 17, 2012.
10. Maharashtra Rains: Mahabaleshwar record 600 mm rainfall in 24 hours. Gaonconnection, July 24, 2021.
11. The Point, Sept. 29, 2022: Hurricane Ian devastates Southwest Florida as one of the most powerful storms to hit the state. By WUFT News. <https://www.wuft.org/news/2022/09/29/the-point-sept-29-2022-hurricane-ian-devastates-southwest-florida-as-one-of-the-most-powerful-storms-to-hit-the-state/>.
12. Climate change likely increased extreme monsoon rainfall, flooding highly vulnerable communities in Pakistan. September 14, 2022. <https://www.worldweatherattribution.org/climate-change-likely-increased-extreme-monsoon-rainfall-flooding-highly-vulnerable-communities-in-pakistan/>
13. Caribbean Disaster Mitigation Project, Concrete Construction.2021. <https://www.oas.org/cdmp/document/codedraw/sectionb.htm>
14. TZuiderzeewet. Nieuwlanderfgoed. January 17, 2009.
15. Huge 3D Printer Can Print an Entire Two-Story House in Under a Day. January 18, 2014. By Lidija Grozdanic. <https://inhabitat.com/large-3d-printer-can-print-an-entire-two-story-house-in-under-a-day/>
16. The underground cathedral protecting Tokyo from floods. By Diego Arguedas Ortiz, November 29, 2018. <https://www.bbc.com/future/article/20181129-the-underground-cathedral-protecting-tokyo-from-floods>
17. World Wildlife Fund 2019 annual report. https://files.worldwildlife.org/wwfcomprod/files/FinancialReport/file/7m1y8wax5s_WWF_AR2019_FINALPAGES.pdf

18. <https://www.bankrate.com/insurance/homeowners-insurance/wildfire-statistics/>
19. Executive Order to Strengthen America's Forests, Boost Wildfire Resilience, and Combat Global Deforestation. <https://www.whitehouse.gov/briefing-room/statements-releases/2022/04/22/fact-sheet-president-biden-signs-executive-order-to-strengthen-americas-forests-boost-wildfire-resilience-and-combat-global-deforestation/>
20. Krasnyansky M. Remote Extinguishing of Large Fires with Powder Aerosols. "Fire and Materials", 30, 2006, p. 371-382
21. A fireproof wood achieves the highest class in burning test thanks to an invisible coating. By Ameya Paleja. https://interestingengineering.com/innovation/invisible-coating-fireproofs-wood?traffic_source=Connatix
22. World Energy Outlook 2021. <https://www.iea.org/reports/world-energy-outlook-2021>
23. How to Design a Net-Zero Home. By Anna FixenBy, July 7, 2020. <https://www.architecturaldigest.com/story/how-to-design-a-net-zero-home>
24. SOM (2020) Pearl River Tower- Sustainable Design. https://www.som.com/projects/pearl_river_tower__sustainable_design Retrieved December 3, 2020.
25. Krasnyansky M (2018) "Energy Saving", textbook. (Ukrainian language), Publishing House "Condor", Kyiv, 134 p.
26. John Wayne. A method of producing meat from farmed muscle tissue for consumption. US Patent 6,835,390.
27. Robin R (2005) Test tube meat. The New York Times.
28. World's largest vats for growing 'no-kill' meat to be built in US. The Guardian, by Damian Carrington, May 25, 2022. <https://www.theguardian.com/environment/2022/may/25/worlds-largest-vats-for-growing-no-kill-meat-to-be-built-in-us>
29. Dickson D (2010) The Vertical Farm: Feeding the World in the 21st Century. New York: Macmillan, 320. - ISBN 1429946040.
31. van Delden SH, Sharath Kumar M, Butturini LJ, et al. (2021) Current status and future challenges in implementing and upscaling vertical farming systems. Nature Food 2: 944-56.
32. UN Environment Program. Food Waste Index Report 2021. March 4, 2021. <https://www.unep.org/resources/report/unep-food-waste-index-report-2021>
33. Lopez E, Barrera T, Hertel T (2021) Global food waste across the income spectrum: Implications for food prices, production and resource use. Food Policy 98: 101874.
34. International Day of Awareness on Food Loss and Waste Reduction. September 29, 2022. <https://www.un.org/en/observances/end-food-waste-day>
35. The role of the ocean in tempering global warming. By Richard Allan, October 23, 2014. <https://www.climate.gov/news-features/blogs/enso/role-ocean-tempering-global-warming>

-
36. Ocean sink for man-made CO₂ measured. ETH Zurich, by Michael Keller, March 14, 2019. <https://phys.org/news/2019-03-ocean-man-made-co2.html>
 37. Barry, Peter G. Brewer James (2008) "Rising Acidity in the Ocean: The Other CO₂ Problem. Scientific American, Sept. 1. www.scientificamerican.com/article/rising-acidity-in-the-ocean/.
 38. Laurent CM, Lebreton T, et al. (2018) Evidence the Great Pacific Garbage Patch is rapidly accumulating plastic. Scientific Reports 8, No. 4666, March.
 39. 64 Pounds of Trash Killed a Sperm Whale in Spain. The New York Times, By Matthew Haag, April 12, 2018.